

SteREO Discovery.V12

Expanding the Boundaries

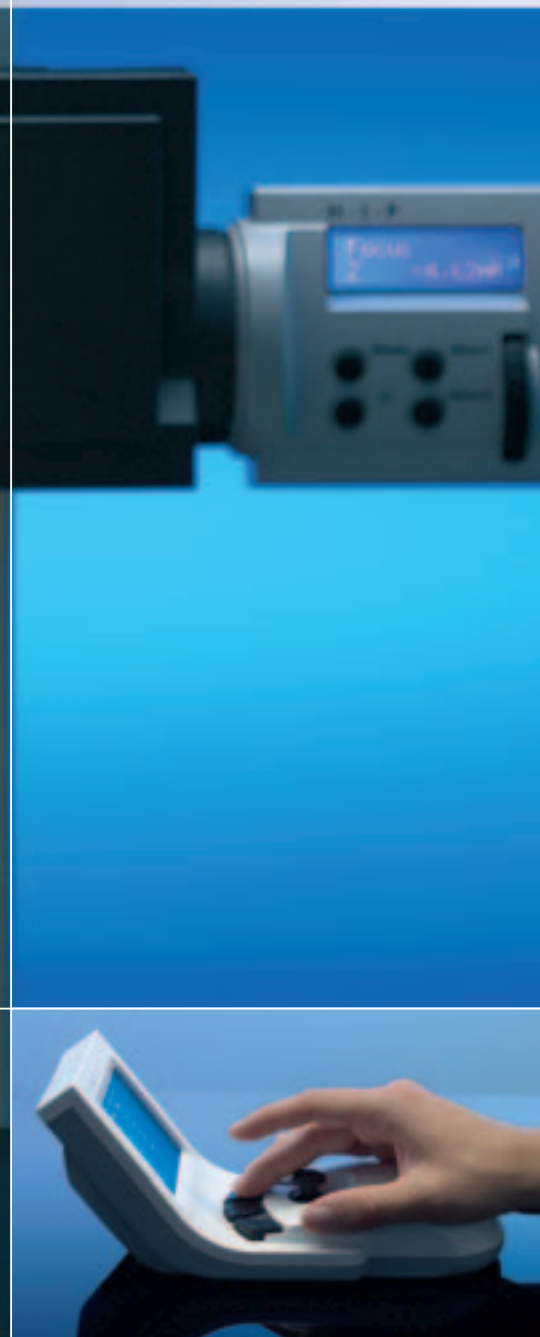

Brilliant images in 3D



We make it visible.

A New Dimension of Performance

New dimensions in operating comfort – with SteREO Discovery.V12. Carl Zeiss is expanding the borders of stereomicroscopy with increase depth of field, excellent color reproduction, high-contrast images and significantly more image information. New patented optics provide improved resolution and contrast. The innovative operating concept SyCoP (Systems Control Panel) combines all essential functions of a stereomicroscope in a single handy operating unit. The sum of these advantages result in increased comfort and efficiency in the laboratory.

With impressive stability and exceptionally large specimen room, SteREO Discovery.V12 is setting new standards in stereomicroscopy – particularly for applications in materials research, quality control, biology and medical research.

Easy operation: SyCoP

Central to the entire microscope operation: SyCoP combines switch, buttons, joystick and touch screen in the handy design of a computer mouse – making operation easy and mobile.



Zoom and focus via joystick...

...Select light and controls...

...all at the touch of a button.

REO Discovery.V12





HIP (Human Interface Panel), a compact operating element, not only replaces the conventional turning knob on the motorized zoom and focus. It also offers additional storage functions and gives information on the current status of the system.

See much more:

The optical concept

Carl Zeiss, optical pioneer and inventor of stereomicroscopy, has invested its entire know-how and expertise in the development of a new optical design for SteREO.Discovery.V12 – with remarkable success. The patented optics are setting new standards in modular common main objective stereomicroscopy. Thanks to higher resolution and significantly increased contrast, they provide 20% more image information – in addition to sensational 3D images.

Flexibility: Intelligent interfaces

The modular design of SteREO Discovery.V12, typical of common main objective stereomicroscopes, offers greater flexibility in the selection of components. In addition, intelligent interfaces enable the use of diverse options from the comprehensive illumination and accessory program from Carl Zeiss.

Superior documentation:

AxioVision, the microscope software

AxioVision, the imaging software from Carl Zeiss, is outstanding in the processing, analysis and archiving of microscopic images. The modular software concept offers individual solutions for all requirements – from the inexpensive entry into digital imaging right up to demanding imaging applications, now often possible for users of stereomicroscopes.

Using the slider on the transmitted light equipment S, you can change the position of the mirror – either matt or polished – to the specimen, thereby optimizing contrast. Reproducible.



SteREO Discovery.V12 has been designed to provide optimal ergonomics and operating comfort. A new ergotube with a camera port enables variable viewing height. The microscopic image reaches the camera without an intermediate tube - in outstanding quality.



A sophisticated system of interfaces and adapters makes it possible to easily attach fiber-optic and LED components for observation and contrasting.



Advantages of the new stand construction of SteREO Discovery.V12: a special Profil S column provides the system with considerably enhanced stability while its lateral positioning creates an enviably large space for the specimen.





*New mechanics for more precision:
the gear rod enables focusing steps with an
impressive 350 nm over range of 340 mm.*

**Brilliance in 3D: Applications
using SteREO Discovery.V12**

High-contrast images with excellent color reproduction, depth of field, high resolution and spatial. Applications with SteREO Discovery.V12 are convincing evidence of the new standard in optics for powerful stereomicroscopes.



*Diatoms
Transmitted-light brightfield
Objective: PlanApo S 1.5x
Magnification: 150x**

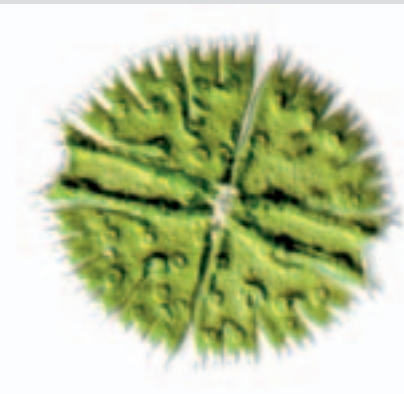

*Desmid algae Micrasterias
Oblique illumination in transmitted light.
Objective: PlanApo S 1.5x
Magnification: 150x* transmitted light*

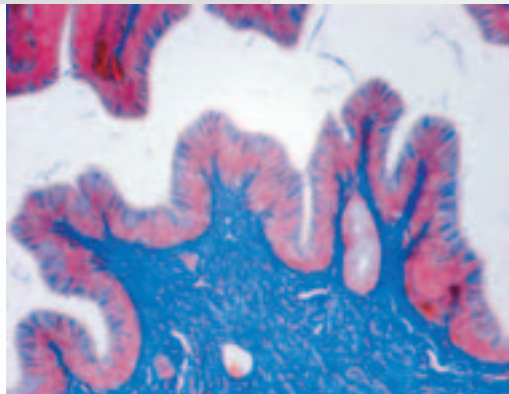

*Frog stained with azan
Transmitted light-brightfield.
Objective: PlanApo S 1.5x
Magnification: 150x**



*Semi-conductor element.
Reflected light-darkfield.
Objective: PlanApo S 1.5x
Magnification: 125x**

** Actual viewing magnification.*

Technical data

Objectives		Eyepieces					
Description	FWD*	WPL 10x/23 Br. foc		PL 16x/16 Br. foc		W 25x/10 foc	
Factor	(mm)	Magnification	Object Field (mm)	Magnification	Object Field (mm)	Magnification	Object Field (mm)
PlanApo S 0,63x	81	5x ... 63x	46 ... 3,7	8x ... 100,8x	32 ... 2,5	12,5x ... 157,5x	20 ... 1,6
Plan S 1,0x	81	8x ... 100x	28,8 ... 2,3	12,8x ... 160x	20 ... 1,6	20x ... 250x	12,5 ... 1
PlanApo S 1,5x	30	12x ... 150x	19,2 ... 1,5	19,2x ... 240x	13,3 ... 1,1	30x ... 375x	8,3 ... 0,7

* Free working distance

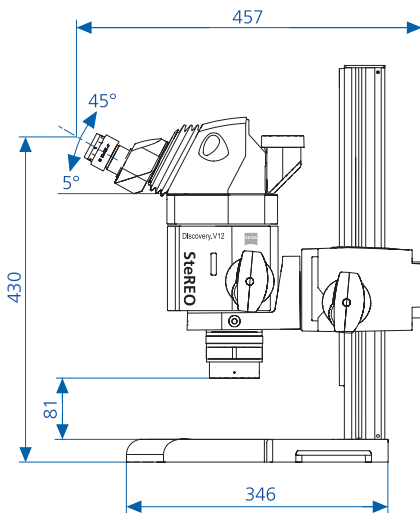

Weight 27,5 kg

